

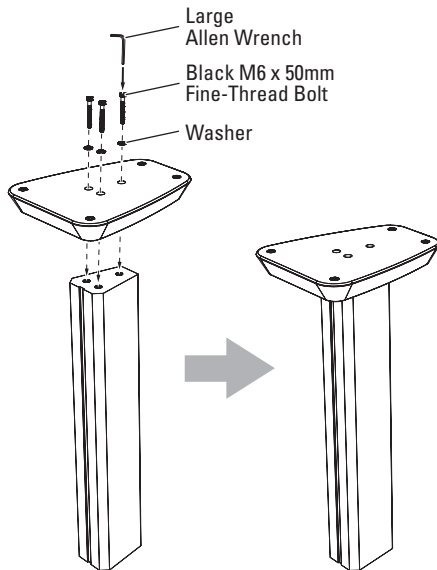

# PERFORMA<sup>3</sup> M Stand Assembly Instructions

**NOTE:** All of the parts shown in the following illustrations are supplied with the M-Stands.

1. Attach the stand base to the stand riser as shown in the illustration below.



2. Spin the clamping rings onto the spikes and insert the spikes into the bases as shown in the illustration below. You can install the spikes with either the pointed end or rounded end protruding from the base.

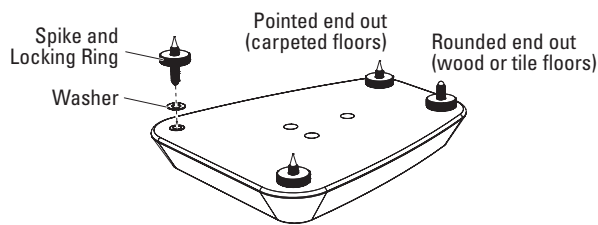

- If the stands are to be placed on a carpeted floor, install the spikes with the pointed ends protruding from the stand base.
- If the stands are to be placed on a wood or tile floor, install the spikes with the round ends protruding from the stand base.

After determining the final locations for the speakers you can place coins under the spikes to protect the floor surface from damage.

**NOTE:** If you wish you can install the spikes with the pointed ends protruding from the stands for placement on wood or tile floors. In this case you must place coins or similar items under the spikes to avoid damaging the floor surface.

Rotate the locking ring clockwise to firmly secure the spike to the cabinet. Make sure to thread the locking rings of all four spikes to achieve a level balance when the stand is placed rightsideup on the floor.

3. Attach the stand top to the stand riser as shown in the illustration below.

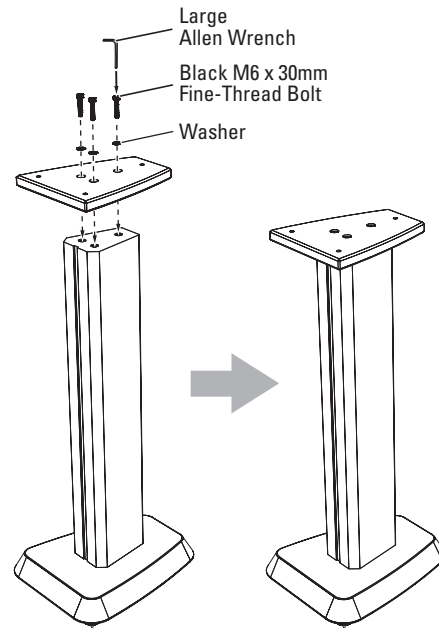

4. Attach the speaker to the stand as shown in the illustration below. Only Revel Performa3 M106 and M105 speakers can be attached to the M-Stand. Use the VELCRO® strap on the rear of the stand for wire management.

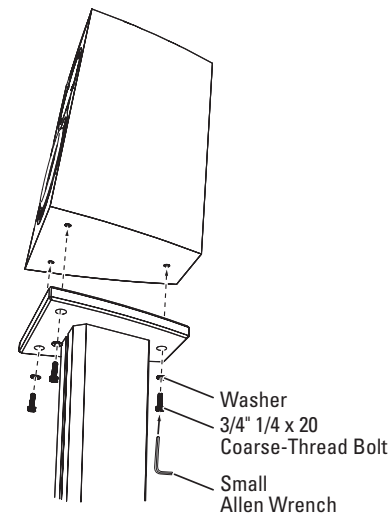



# PERFORMA<sup>3</sup> C Stand Assembly Instructions

**NOTE:** All of the parts shown in the following illustrations are supplied with the C-Stands.

1. Attach the stand base to the stand riser as shown in the illustration below.

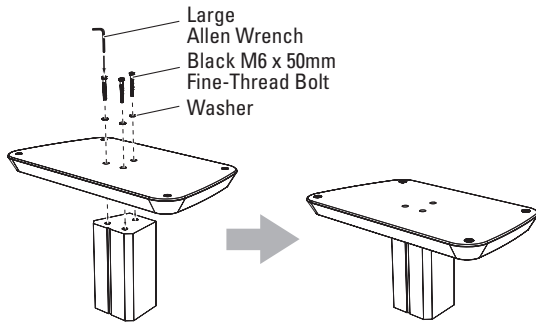

2. Spin the clamping rings onto the spikes and insert the spikes into the bases as shown in the illustration below. You can install the spikes with either the pointed end or rounded end protruding from the base.

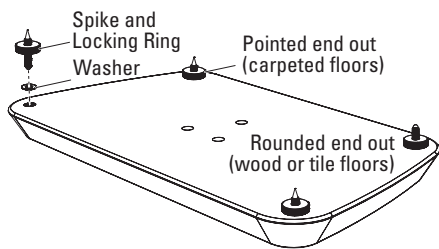

- If the stand is to be placed on a carpeted floor, install the spikes with the pointed ends protruding from the stand base.
- If the stand is to be placed on a wood or tile floor, install the spikes with the round ends protruding from the stand base.

After determining the final locations for the speakers you can place coins under the spikes to protect the floor surface from damage.

**NOTE:** If you wish you can install the spikes with the pointed ends protruding from the stands for placement on wood or tile floors. In this case you must place coins or similar items under the spikes to avoid damaging the floor surface.

Rotate the locking ring clockwise to firmly secure the spike to the cabinet. Make sure to thread the locking rings of all four spikes to achieve a level balance when the stand is placed rightsideup on the floor.

3. Attach the stand top to the stand riser as shown in the illustration below.

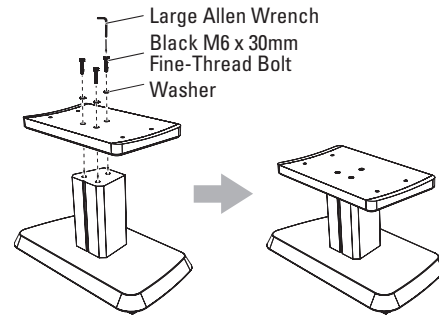

4. Attach the speaker to the stand as shown in the illustration below. Only Revel Performa3 C208 and C205 speakers can be attached to the C-Stand.

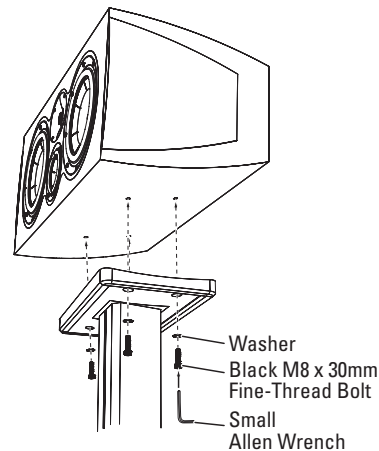

**IMPORTANT:** If you are attaching the C208 or C205 to the C-Stand you cannot use the adjustable feet that were included with the speaker. The C-Stand places the speaker at the proper angle for seated listeners without requiring additional adjustments.

## HARMAN

HARMAN International Industries, Incorporated  
8500 Balboa Boulevard, Northridge, CA 91329 USA

© 2012 HARMAN International Industries, Incorporated. All rights reserved.

Revel and the Revel logo are trademarks of HARMAN International Industries, Incorporated, registered in the United States and/or other countries.

VELCRO is a registered trademark of Velcro Industries B. V.

Features, specifications and appearance are subject to change without notice.

For questions, assistance or additional information concerning any of our products, call us at: (516) 594-0300 or (888) 691-4171. For technical support, submit your detailed inquiry to: [csupport@harman.com](mailto:csupport@harman.com).

Part No. REVP4838 Rev: A

[www.revelspeakers.com](http://www.revelspeakers.com)